

# EK220

Electronic volume corrector  
with flexible data logging function  
and configurable serial interface



## Applications

- Volume correction for billing purposes
- Data logging for different applications
- Monitoring of measurement values und station functions

## Brief information

The EK220 is a battery-operated volume corrector. The device records the low frequency operating volume pulses of a gas meter, measures the operating pressure and temperature of the gas and calculates the compressibility K as well as the conversion factor C. The standard volumes, standard flow rates and operating flow rates can be calculated using this initial data.

The volume corrector consists of a central unit with either an integrated or external pressure sensor and a temperature sensor. The sensors are permanently connected to the unit. The compressibility K can be programmed as a constant for all gases or calculated according to various methods of calculation.

The EK220 can be used in many applications in the field of natural gas measurement and station monitoring thanks to four digital outputs, a flexible data logging function in conjunction with a freely configurable serial interface and different communication protocols.

Additional components for explosion-proof isolation of the interfaces and the intrinsically safe external voltage supply, and for data communication, extend the range of use of the volume corrector.

## Station monitoring

In addition to volume correction and data logging, the EK220 may be used for the flexible data recording of different measurements and, in conjunction with either a modem or RTU, for system monitoring.

Two additional digital inputs can be used for registering and monitoring the signal sensors such as the safety shut-off valves on regulators, the differential pressure switches in filters or for a simple door contact. The signals from such sensors can be saved in an archive as an event and can also be sent as a spontaneous message by text message or by e-mail via a connected modem.

The volume corrector may optionally be fitted with a second external pressure sensor, which allows to record the inlet or outlet pressure of the measuring system, or to monitor its limit values.

## Main features

- System volume corrector
- Conforms to European standard EN 12405
- MID approval
- Compressibility calculated in accordance with different methods
- Flexible, integrated data logging function
- High accuracy
- Mains-free operation
- Suitable for use in Zone 1 hazardous areas
- Three digital inputs
- Four freely programmable, sealable digital outputs
- Various communication protocols
  - IEC 62056-21
  - Modbus
  - IDOM
- Optical interface for parameterisation and readout (IEC 62056-21)
- Configurable serial interface can be used as RS232 or RS485
- Second pressure sensor for monitoring purposes (option)

# EK220: Electronic volume corrector

## Display and operation

The current values and parameters can be shown on the two-line, alpha-numerical display and changed if required. The use of four arrow keys guarantees simple navigation of data arranged in lists. Each value is displayed with a clear description and the relevant unit.

For everyday operation, the most important values are combined in a configurable user list. The display range can be limited to this list, which will guarantee simple operation of the volume corrector at the metering point. At the touch of a few buttons, the current meter readings and the main operating parameters can be checked.

## Data logging function

The integrated, event-triggered data logger supports different archive and logbook functions.

Six archives can be freely configured, i.e. the values that are to be recorded, the events triggering registration, as well as the recording interval (measuring period), can be selected as required. Depending on an archive's configuration, the data can be saved for up to one year, or longer.

Along with the data logging archives, the volume corrector offers three logbooks, with which the volume corrector's operation can be monitored constantly. The event logbook saves the last 500 messages for events and status changes. In the change logbook the last 200 setting changes are registered and up to 50 changes to parameters and values requiring official calibration are documented in the calibration archive (Certification data log).

## Communication interface

The programming or readout of the device at the station is performed via the optical interface (IEC 62056-21) on the front panel.

The unit's serial interface can be freely configured and can be operated in RS232 or RS485 mode. It allows connection to modems and other communication components. In RS485 mode, bus operation is also possible, in order to read out two volume correctors via a communication module (modem, RTU). In compliance with the specifications laid out in the ATEX approval, the interface may also be used in hazardous areas in any configuration.

## Communication protocols

The EK220 supports various communication protocols. Invoice-relevant data or process and operating data for network management can therefore be used simultaneously in many established central call-up systems and EDM systems.

Using the communication protocol in accordance with IEC 62056-21, all parameters can be read and changed and the archives can be read out. All protocol information is disclosed and is available on request for the development of own applications and call-up systems.

As an alternative to the protocol in accordance with IEC 62056-21, the Modbus protocol can also be used for data communication via the internal interface, which allows connection to SCADA systems. Modbus/RTU and Modbus/ASCII operating modes are supported.

In order to guarantee the greatest flexibility as regards different requirements, the data elements, associated indicators and data formats can thus be freely configured.

## Additional functions

Two additional digital inputs can be used either as pulse inputs or status inputs for various applications, such as station monitoring and pulse comparisons, for example.

Four freely programmable digital outputs enable a range of information to be transmitted. When programmed as pulse

outputs, they allow forwarding of the volume pulses determined for a measuring cycle in the form of pulse packets. When used as status outputs, messages and warnings can be signalled on the basis of different results (e.g. exceeding the minimum or maximum consumption values or measured values, sensor errors, time synchronisation signals, etc.). The outputs can either be secured against unauthorised changes by supplier lock or calibration lock.

The volume corrector may also optionally be fitted with a second pressure sensor. Depending on the system configuration, the measuring system's inlet or outlet pressure can thus be registered in one of the flexible archives and the limit values can also be monitored there. The system's status can also be continuously monitored when it is connected to a SCADA system.

## Power supply

The power supply for the unit is provided by a lithium battery. In standard operation, the service life of the battery is 5 years. An optional additional battery can be used to double the battery life. The current operating status of the volume corrector is taken into account when calculating the remaining battery capacity. If the battery life is 3 months or less, the corresponding indication appears in the display. In addition, this information can also be called up via the volume corrector status register. The battery can be replaced without damaging the internal seals. All parameters are saved in a non-volatile memory.

In addition, it is also possible to use an external power supply. In this case, the battery remains in the unit and guarantees the unit functions, including if there is a failure of the external power source.

## Version

For wall mounting, the housing of the EK220 is equipped with boreholes. It can also be fitted directly to the meter or gas pipe using an attachment bracket.

## Second pressure sensor for station monitoring (option)

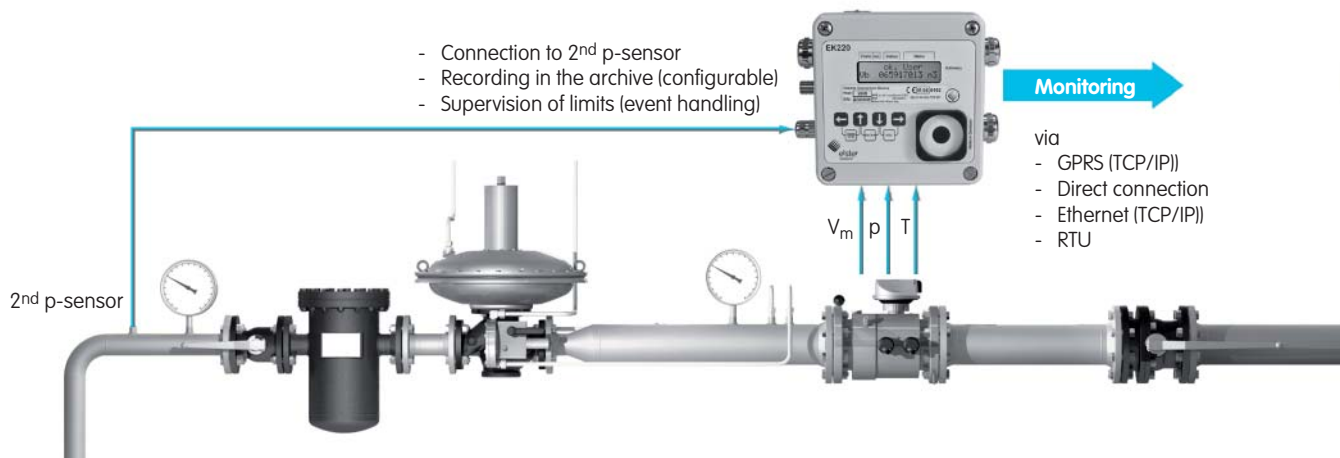

## Flexible data logging and logbook function

Archive	Content	Interval	Capacity	Flexible	LIS-200 compatible
Standard configuration					
Monthly 1	Date, Time, $V_m$ , $V_{mtr}$ , $MP_{maxVm}$ , $Daily_{maxVm}$ , $V_b$ , $V_{btr}$ , $MP_{maxVb}$ , $Daily_{maxVb}$	monthly	24 months	-	x
Monthly 2	Date, Time, $Q_{mmax}$ , $Q_{bmax}$ , $Q_{mmin}$ , $Q_{bmin}$ , $P_{max}$ , $p_{min}$ , $p\emptyset$ , $T_{max}$ , $T_{min}$ , $T\emptyset$ , k-value $\emptyset$	monthly	24 months	-	x
Daily	Date, Time, $V_m$ , $V_{mtr}$ , $V_b$ , $V_{btr}$ , $p\emptyset$ , $T\emptyset$ , k-value $\emptyset$ , C factor $\emptyset$ , Status	daily	18 months	-	x
Measurement 1	Date, Time, $V_m$ , $V_{mtr}$ , $V_b$ , $V_{btr}$ , $p\emptyset$ , $T\emptyset$ , k-value $\emptyset$ , C factor $\emptyset$ , Status	1 minute - 1 month	1 month	-	x
Measurement 2	Date, Time, $V_m$ , $V_{mtr}$ , $V_b$ , $V_{btr}$ , $p\emptyset$ , $T\emptyset$ , k-value $\emptyset$ , C factor $\emptyset$ , Status	1 minute - 1 month *3	6 months	x	x *2
Process data	Date, Time, $V_m$ , $V_{mtr}$ , $V_b$ , $V_{btr}$ , $p\emptyset$ , $T\emptyset$ , k-value $\emptyset$ , C factor $\emptyset$ , Status	1 minute - 1 hour *3	*1	x	-
Additional 1 - 4	Flexible	1 minute - 1 month *3	*1	x	-
<b>Logbooks</b>					
Event	Date, Time, Event	every event	500 records	-	x
Audit trail	Date, Time, Parameter, Old value, New value, Information for all locks	every change	200 records	-	x
Certification data log	Date, Time, Parameter, Old value, New value, Information for all locks	(every change) *4	50 records	-	x

\*1 depends on configuration of archive (interval, content)

\*2 by using the standard configuration

\*3 beside the frequently recording also free selectable events can be used for recording

\*4 records only the changes of values, which are under the calibration lock (function can be switched off)

## FE260 function extension unit – a flexible interface between EK220 and energy data management

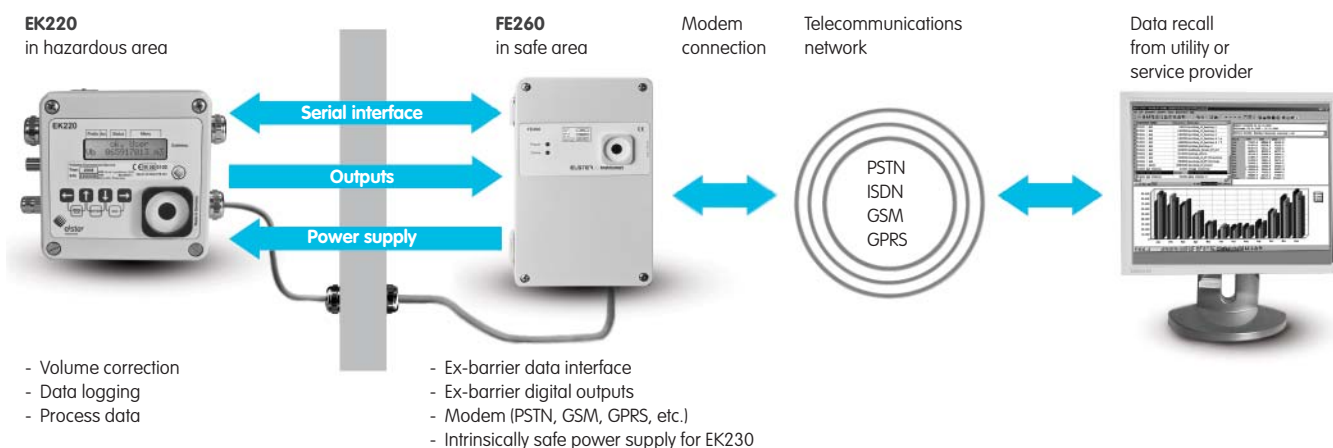

The Ex-barrier of the serial interface and the pulse outputs of the volume corrector are provided by the FE260 function ex-

ension unit. In addition, the intrinsically safe power supply of the volume corrector is guaranteed. The unit's modular

concept allows the use of a modem for data communication or an interface for connection to other devices.

# EK220: Electronic volume corrector

Technical data	
Order number	83462550
Housing	Cast aluminium, wall or meter mounting
Dimensions	H 126 mm x W 120 mm x D 90 mm (not including connections)
Weight	Approx. 1.5 kg (including batteries)
Metrological approval	Conforms to the European standard EN 12405-1: 2005 +A1: 2006 MID DE-08-MI 002-PTB 001 volume conversion device for gas (pTZ-conversion)
ATEX approval	Zone 1, EEx ia IIC T4
Protection class	IP 66 (suitable for outdoor installation)
Ambient conditions	Temperature: -25 to +55 °C
Battery power supply	1 lithium battery module (service life > 5 years under standard operating conditions) Optional additional battery to double the service life
External power supply	5 – 10 V DC, I < 30 mA mains power supply unit (in conjunction with a serial interface)
Control panel	Keypad with 4 buttons
Display	2-line dot-matrix display with plain-text description of the values displayed. All parameters, settings and archived values can be displayed.
Inputs	3 digital inputs for connecting LF pulse generators and message signals (e.g. manipulation contact)
Pressure sensor for volume correction	Absolute sensor, Type ENVEC CT30*, integrated in housing or, as an option, provided as an external sensor (in case of using the second pressure sensor this sensor is always integrated), connection for precision steel pipe (Ermeto 6L) or flexible pressure tube, M12 x 1.5 thread Pressure ranges 0.7 – 2 bar / 0.8 - 5 bar / 1.4 - 7 bar / 2 – 10 bar / 2.4 - 12 bar / 4 – 20 bar / 6 - 30 bar / 8 - 40 bar / 14 – 70 bar / 16 – 80 bar * Other sensor and pressure ranges on request
Pressure sensor for monitoring purposes (option)	Absolute or gauge sensor, Type ENVEC CT30, provided as an external sensor, fixed connected to the central unit, cable length fix 10 meter connection for precision steel pipe (Ermeto 6L) or flexible pressure tube, M12 x 1.5 thread Absolute pressure ranges between 0.7 – 80 bar (see above) Gauge pressure ranges: 1.4 - 7 bar / 4 – 20 bar / 16 – 80 bar
Temperature sensor	Pt-500 (or Pt-100 as an option) resistance thermometer to DIN 60751 with protective tube, for use with thermowell. - Fitting length 50 mm Ø 6 mm, length of supply cable 2.5 m
Compressibility	Calculation in accordance with S-GERG 88, AGA 8 (GC1 or GC2), AGA NX-19, AGA-NX19 following Herning & Wolowsky or fixed
Archives	2 Monthly-, 1 Daily-, 1 Measurement archive (content and recording interval are fix) 1 Process data archive, 1 Measurement-, 4 additional flexible archives (content, recording interval and additional events which cause a record can be selected)
Logbooks	Event logbook - Recording of non-periodic events (e.g. time changes with time stamp) - Storage capacity 500 records Change logbook (Audit trail) - Recording of all parameter and value changes (time stamp, old and new values) - Storage capacity 200 records Certification data log - Recording of changes of parameters and values (time stamp, old and new values) which are under the access right of calibration lock - Storage capacity 50 records
Signal outputs	4 digital transistor outputs, freely programmable and protectable via calibration lock as - Pulse output for all operating or standard volume meters - Signal output for alarm and/or warning status information
Data interface	Optical interface in accordance with IEC 62056-21 Internal serial interface usable as RS232 or RS485
Communication protocols	- IEC 62056-21 (IEC1107) - Modbus ASCII / RTU - IDOM-Protocol - SMS Other communication protocols on request

## Your contacts

Germany  
Elster GmbH  
Steinern Str. 19 - 21  
55252 Mainz-Kastel  
T +49 6134 605 0  
F +49 6134 605 223  
www.elster-instromet.com  
info@elster-instromet.com

Belgium  
Elster-Instromet N.V.  
Rijkmakerlaan 9  
2910 Essen  
T +32 3 670 0700  
F +32 3 667 6940  
www.elster-instromet.com  
info@elster-instromet.com

Singapore  
Elster-Instromet  
Singapore Representative Office  
80 Marine Parade Road  
09-04 Parkway Parade  
Singapore 449269  
T +65 6247 7728  
F +65 6247 7729

EK220 EN01

A27.06.2008