

WHAT'S NEW ABOUT M2R ?

More features for the ELSTER medium-pressure 2-stage Regulator – M2R

The M2R 2-stage regulator was first introduced in 1998. Since then, it has undergone a further extensive overhaul to improve its performance and increase the variety of possible features.

Due to the basic modular concept it is possible to supply a large number of different connections and equipment features in order to meet individual customer requirements.

The standard meter installation shown in the diagram can be adapted by choosing from different inlet and outlet connections and can be made to suit a variety of needs. Here, we have only given a few examples:

M2R Dimensions

- A 60 mm, B 103 mm**
inlet: $\frac{3}{4}$ " nut, sphero conic
outlet: $1\frac{1}{4}$ " meter connector
- A 60 mm, B 100 mm**
inlet: $\frac{3}{4}$ " nut, flat joint
outlet: $\frac{7}{8}$ " meter connector
- A 60 mm, B 117 mm**
inlet: $\frac{3}{4}$ " female thread
outlet: 1" female thread
- C 150 mm, in line**
inlet: $\frac{3}{4}$ " nut, sphero conic
outlet: $1\frac{1}{4}$ " meter connector

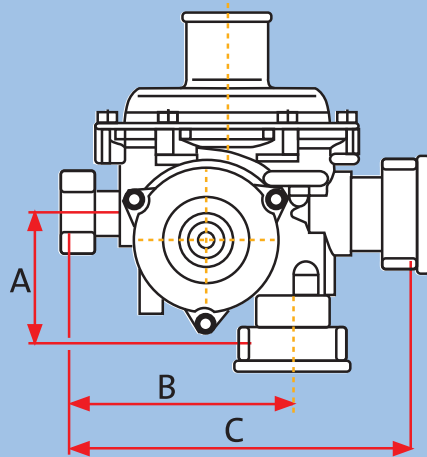

On top of these, there are many other connection possibilities and combinations available.

In addition to this, the performance of the device has also been greatly improved in terms of flow capacity and outlet pressure range:

- ▶ The flow capacity has now been extended to 25 m³/h at an inlet pressure range of 0.7 to 5 bar (see flow diagram).
- ▶ The outlet pressure range has been extended to 150 mbar
- ▶ A special version for an outlet pressure range above 150 mbar up to 400 mbar is now also available.



As far as the safety installations are concerned, there are also a number of different options available:

- ▶ Relief valve integrated in the 2nd stage of the regulator or, alternatively, a safety diaphragm for a safe indoor installation.
- ▶ Low-pressure cut-off valve (LPCO) also working as an excess flow valve (EF) or even without an LPCO/EF device.
- ▶ The EF can be preset to capacities of 2.5, 4, 6, 10, 25 m³/h.
- ▶ The LPCO/EF is available either with a manual or an automatic reset.
- ▶ For fire-safe indoor installations the inlet connector can be fitted with a thermal cut-off valve (TCO)

One feature which should be highlighted is the possibility of combining the LPCO/EF with an automatic reset. Where are the advantages in doing this? With the automatic reset it is possible to save a lot on maintenance costs, especially in more widespread supply areas.

How does it function?

When the supply pressure drops, the outlet pressure also drops and this opens the regulator valve until the low-pressure cut-off plate closes against the seat of the valve and shuts off the flow of the gas. If the supply pressure then increases again, a small amount of gas flows through a by-pass in the low-pressure cut-off plate into the pipe system downstream. If all of the consumer points downstream from the regulator are closed, then the outlet pressure automatically builds up and the regulator activates itself once again. The graded activation of the LPCO shown in the diagram is a reliable method of preventing an unwanted rise in pressure at the outlet side.

When a consumer point downstream is open, only a small amount of gas can pass through. Since there is no possibility of pressure compensation, the LPCO remains closed.

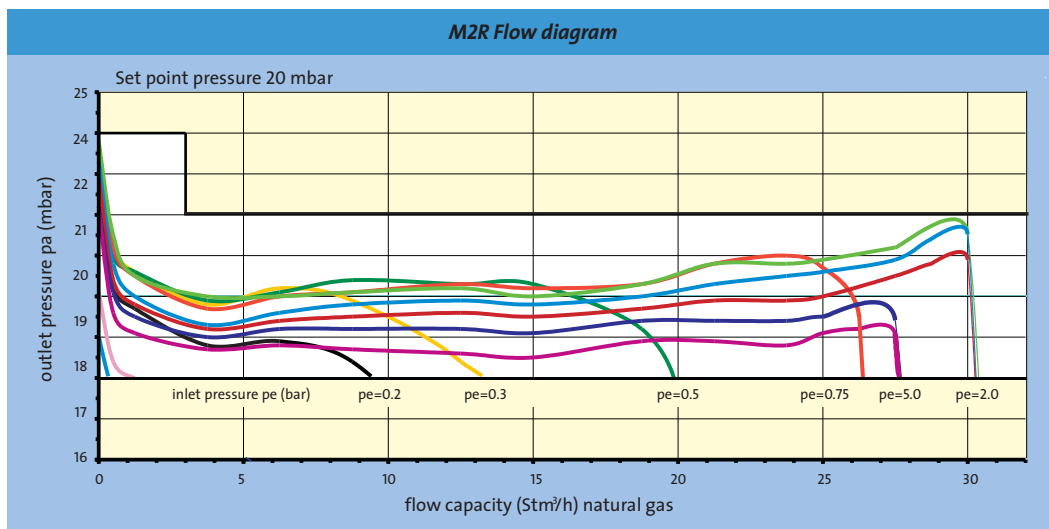

Arguments for an automatic reset of the LPCO:

- ▶ The LPCO closes the regulator when the inlet pressure drops as a result of maintenance work or any damage in the distribution network or if the downstream flow exceeds the maximum capacity.
- ▶ When the gas supply is switched on again, the regulator opens automatically if the outlet side is closed.
- ▶ When the shut-off valve downstream from the regulator is open and the gas consumption devices in use have no safety ignition (for example a cooker without a safety ignition), then the regulator remains closed.
- ▶ The automatic reset helps to reduce maintenance costs for the regulator. It is no longer necessary to manually release the regulator after the gas supply has been cut off, a process which has always involved high time and labour costs. This means that long journeys to remote areas and long waiting times can be avoided.

The automatic reset system we have described here has become more and more popular in an increasing number of markets simply because of its huge cost-saving potential.

On account of the varied combination possibilities concerning the connection, safety and performance features, it is possible to realise a wide range of customized solutions. This makes the Elster M2R a highly flexible device.

PAUL LADAGE, ELSTER GERMANY ladage@elster.com

