

TRZ 2 SUCCEEDS ETM

# The new advanced ELSTER Turbine Meter line

The increased requirements which have been established in all turbine gas meter markets have led ELSTER to rework the existing ETM turbine gas meter line. The result is a new turbine meter generation with the name TRZ2 (Fig. 1).

The "2" in the name stands first of all for the very short inlet length of just two diameters (2D) but also to indicate the new generation of turbine meter. The advantages of the new TRZ2 turbine meter line for the customer are manifold. Apart from the short inlet length of 2D, one other key factor is the easy and flexible system capability. Both aspects together allow for a very compact design of a highly-sophisticated gas measuring system.

ween the perturbation and the gas meter, means that the flow can compensate its disturbed profile on its own. The longer this inlet pipe is, the better it is for the flow. Unfortunately, this conflicts with the demand for compact design. It is now the job of the inlet flow guide to straighten the remaining disturbance before the gas reaches the turbine wheel and to do so in such a way that a short inlet pipe such as 2D is in fact sufficient.

### 2D Inlet Length

This is exactly what we have achieved with the newly developed inlet flow guide in the TRZ2. The unique design with the orifice ring (Fig. 2) and the exactly balanced parameters such as channel



Fig. 1: New advanced ELSTER Turbine Meter TRZ2

Typically, the designer of gas measuring stations tries to keep the space required as small as possible, particularly in the case of a system which has to fit into a cabinet. This might not be such an easy job if the system consists of a regulator followed downstream by a turbine gas meter. The problem is the asymmetric flow profile behind a regulator, which gets even worse if the regulator is followed by an elbow or especially by a double elbow before the gas enters the turbine gas meter. A straight pipe in the meter inlet, i.e. bet-

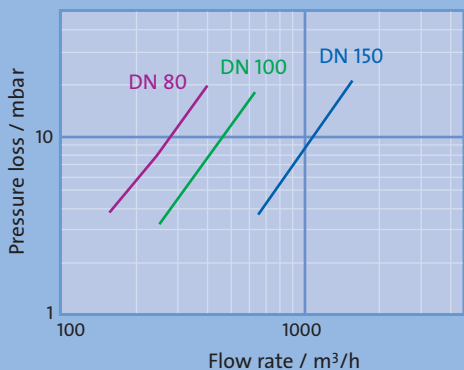

Fig. 2: ELSTER unique orifice ring is a major element of the inlet flow guide

height, blade numbers, blade length etc. make it possible to have an inlet length of only 2D.

The new design naturally meets the accuracy requirements stipulated by all major European and international standards (e.g. EN12261 or OIML R32). The skill of this lies in the fact that we have achieved these standards without increasing the pressure loss of the meter, which is unfortunately often the case. As the pressure loss diagram in Fig. 3 shows, with the TRZ2 the goal has been achieved.

Fig. 3: Pressure loss diagram of the TRZ2



So, the TRZ2 combines compact installation with low pressure loss. Figure 4 illustrates one possible extreme case where a regulator is 2D upstream of the TRZ2 turbine meter. The example also points out that a certain outlet length is not necessary for the TRZ2 in general. The meter outlet can be directly followed by an elbow, for example. Of course, the working position is flexible, i.e. horizontal and vertical are both possible.

**Compact Flexible System Capability**

In order to enable compact, flexible and easy system capability, the TRZ2 option concept has changed compared to the ETM. While thermowells or high frequency pulse generators were not available for the ETM, they are now optional in the TRZ2 series. With the standard aluminium turbine wheel the user is able to choose the high

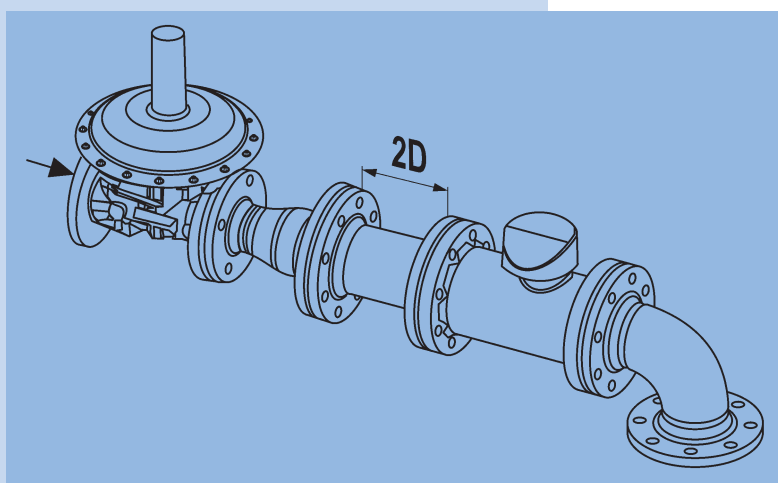

Fig. 4: Compact installation: TRZ2 Turbine Meter 2D downstream from a regulator



Fig. 5: TRZ2 with integrated thermowell and LF-pulsar combined with an EK230 volume corrector as pre-calibrated gas measuring system

frequency pulser option. When choosing the entire gas measuring system consisting of a volume corrector and turbine meter, which is completely calibrated exworks (Fig. 5), it is necessary to have a thermowell integrated in the gas meter. This is also a possible option with the TRZ2 line. The built-in thermowell not only have practical advantages, it is also a quality feature of accurate gas measurement. The integrated thermowell measures the temperature of the gas in the flow channel of the turbine meter, which is in the same state as it is for the pressure and the volume measurement. Because the state of the gas inside and outside the turbine meter is different, the accuracy of the gas measurement suffers when a thermowell is not integrated.

One success factor of the ETM line was the very attractive price-performance ratio, even though the range of options was limited to those which were absolutely necessary. This attractive price strategy will be continued with the TRZ2 line. The TRZ2 is available in diameters ranging from DN80 to DN150 and for pressure ratings ANSI150 and PN16. As mentioned above, an integrated thermowell and a high-frequency pulser are also available as an option. Naturally, the TRZ2 turbine meter line also includes the unique ELSTER measuring cartridge.

Serial production of the TRZ2 is planned for the 4th quarter of 2004.

We are positive you will agree with us that the new TRZ2 with its advanced performance and modern production processes fits as perfectly into the world of gas metering as a key does in its lock.

DR. HARALD DIETRICH, ELSTER GERMANY

dietrich@elster.com