

High tech from Elster protected by patent: Q.Sonic[®]plus – the next generation

For over 15 years, the name Q.Sonic has been synonymous with high-precision ultrasonic gas meters which are used for the calibrated measurement of natural gas. More than 6000 of these high-tech gas meters are now in use around the world.

Q.Sonic is also intrinsically linked to a unique arrangement of ultrasonic measurement paths, a combination of two double reflection paths (swirl paths) and one to three single reflection paths (axial paths) which only Elster-Instromet is able to provide in this form.

The new Q.Sonic^{plus} now continues this tradition. Based on the long-term positive experience with reflection path technology, we have once again chosen a clever path arrangement which works with four double and two single reflection paths. A thorough analysis of the previous Q.Sonic model showed that there were several areas with potential for improvement, for example by making the arrangement symmetrical. This made it necessary to use two additional double reflection paths, whereby the paths are now arranged in pairs, each pair on one level, creating a

completely symmetrical structure. Elster-Instromet has once again been awarded a patent for this path configuration and is therefore the only supplier in the world that provides this path arrangement.

Despite these additional paths, the aim was to achieve an optimum housing length. For this reason, the designers redeveloped the ultrasonic transducers and their mounting plate. All nominal meter sizes up to ANSI 600 can now be supplied with a design length of $3 \times D$. The new transducers with the type designation NG are much smaller and also feature an intrinsically safe design. As before, the new mounting plate allows the transducers to be replaced without depressurizing the whole system. We can also supply a newly developed assembly tool for this purpose.



Transducer with mounting plate

Another innovation of the Q.Sonic^{plus} is that it can be equipped with a pressure and temperature measurement function. This means that the device measures both the gas pressure and temperature of the measuring tube. On the one hand, these measurements allow for a more accurate calculation of the Reynolds number for a flow profile analysis and on the other, they can be used to correct the housing diameter. This is useful if the process conditions differ massively from the conditions during the calibration process since both high pressure and high temperatures result in an increase in the tube cross-section. This can, in fact, produce an additional measurement error if it is not taken into account.

Probably the biggest change compared to the previous model is the electronics unit. This features a completely redeveloped modular hardware and software platform, which will be used in many Elster-Instromet devices in the future and also provides plenty of reserve to meet future requirements. The operating system used in the device, Integrity from Green Hills, is regarded as one of the most secure systems in the world and for this reason, it is also used in the aircraft industry. The application

Advantages of the new path arrangement

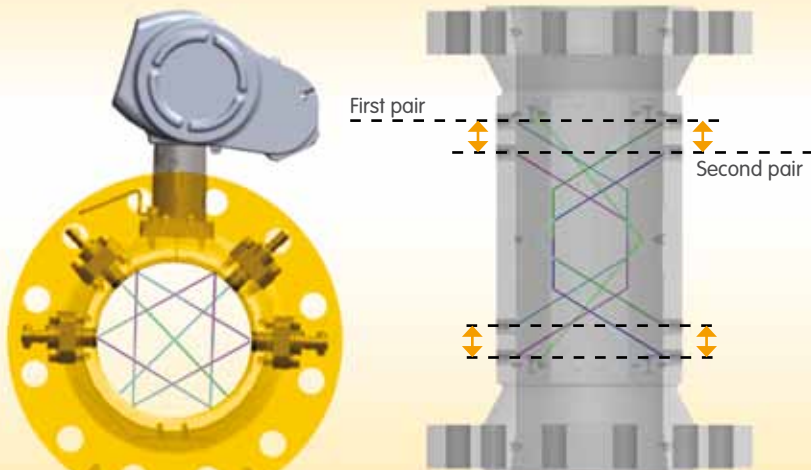

The mean value of both pairs gives a symmetrically weighted measurement.

software which runs on it allows the strict separation of the fiscal from the operational function and therefore permits the range of functions to be extended without additional approvals being required as long as the fiscal modules are not affected. This means that new customer requirements relating to diagnostics, archiving or data communications, for example, can be satisfied with considerable ease.



Electronics housing with display

The modular hardware design with a free slot is also prepared to tackle future requirements. The first expansion cards, for example for connecting external pressure and temperature sensors so as to integrate a volume correction function in the ultrasonic gas meter, are already being developed.

The electronics are located in a pressure-tight enclosed housing (Ex-d) with a separate connection panel. Despite the selected protection class, it has nevertheless been possible to design the system with a full graphics display with touch screen function. This features contact-sensitive sensors located under a pane of glass which is more than 10 millimetres thick. This means that all the data which the Q.Sonicplus supplies can be retrieved without requiring any other equipment.

For data transfer, the connection panel includes two serial interfaces (RS 232 full duplex/RS 485 half duplex), which can be configured by software, as well as an Ethernet connection. It also contains two frequency outputs and two pairs of terminals, which can be used as digital or analogue outputs.

A VDSL (very high speed digital subscriber line) modem can also be installed on

request. When combined with a VDSL modem at the opposite end, this allows simple two-wire screened cables to be used for high-speed data transfer over distances of up to four kilometres. This option is becoming increasingly important for handling large volumes of data and large distances between the metering point and the control room since an Ethernet connection is restricted to a length of just a few hundred metres while serial connections are not designed for transferring large volumes of data. The internal memory of the Q.Sonicplus can be up to 16 gigabytes in size.

There is a USB port under the side cover for parameterizing and reading the archive data. However, the Ethernet interface in the connection panel

can also be used for this purpose.

Some changes have also been made to the meter housing. The use of intrinsically safe ultrasonic transducers means that there is no longer any need for complicated connection boxes. The cover now consists

of two stainless steel shells which, in addition to design aspects, are mainly provided to protect the cable connections.

In addition, we have standardized the internal diameter of the measuring tubes for nominal sizes up to 16" (DN 400). There are now two diameters to choose from for each nominal size. The diameter is adjusted to the required diameter in the inlet and outlet sections by means of a taper which is designed to ensure that it does not adversely affect the measurement accuracy. For larger nominal sizes, Elster-Instromet will continue to supply the meters on the basis of the required internal diameter.

The development of the Q.Sonicplus has now entered its final stage, production preparation. Once all the required basic licensing procedures for MID, ATEX, IECEx, FM and CSA have been completed, the new ultrasonic gas meters will be available for delivery as from the second quarter of 2012.

If you would like to arrange an appointment with our experts, we will be delighted to demonstrate the finer points of this high-tech ultrasonic gas meter to you. Then you can see for yourself what this modern concept offers and how it can protect your investment for the future.

Jürgen Wolff

juegen.wolff@elster.com

Housing type	Meter size		Flanged connection		Internal diameter [m]	Flow rate [m³/h]	
	inch	DN	ANSI schedule	DIN		Q _{min}	Q _{max}
Fixed internal diameters	4	100	STD - XS	2633 - 2635	0.097	13	1,100
			XS - 100			11	1,000
	6	150	STD - XS	2633 - 2635	0.146	18	2,200
			XS - 120			16	2,000
	8	200	STD - XS	2632 - 2635	0.190	30	4,000
			XS - 120			27	3,500
	10	250	STD - 80	2632 - 2635	0.240	48	6,000
80 - 120			44			5,500	
12	300	30 - 60	2632 - 2635	0.295	73	8,500	
		60 - 100			66	8,000	
14	350	30 - 60	2632 - 2635	0.325	85	10,000	
		60 - 100			75	9,000	
16	400	30 - 60	2632 - 2635	0.370	115	13,000	
		60 - 100			100	11,500	
Selectable internal diameters	18	450	STD	N/A	0.4413	160	18,000
			120			120	14,000
	20	500	STD	2632	0.4889	200	21,000
			120			2635	158
	24	600	STD	2632	0.5905	290	29,600
			120			2634	230
	26	650	STD	N/A	0.6223	320	33,000
			120			0.5715	277
	30	750	STD	N/A	0.7366	460	46,000
			120			0.6604	360
	36	900	STD	2632	0.8890	670	67,000
120			2634			526	53,000
42	1050	STD	N/A	1.0414	910	83,000	
		120			0.9398	740	68,000
48	1200	STD	2632	1.1938	1,200	110,000	
		120			2633	1,012	92,000
56	1400	STD	2632	1.3970	1,650	150,000	
		120			2633	1,590	144,000